

# SIERRA

REVERSE OSMOSIS DRINKING WATER SYSTEM



**Nimbus**  
WATER SYSTEMS

41840-A McAlby Court, Murrieta, CA 92562  
(800) 451-9343, email: [sierra@nimbuswater.com](mailto:sierra@nimbuswater.com)

Please fill out the following information at the time of installation. Save for future reference.

Model: Sierra NS-1N30-00

Date Code: \_\_\_\_\_

Install Date: \_\_\_\_\_

Sold by: \_\_\_\_\_

Installed By: \_\_\_\_\_

Service Center  
Phone Number: \_\_\_\_\_

# SIERRA Introduction To The Sierra

Congratulations on your purchase of the Nimbus Sierra reverse osmosis system. When properly maintained, this system will provide you with years of trouble-free service. The next sections contain important information on proper care and maintenance. Please take a few minutes to read through this information.

The cartridges in this system must be replaced on a regular basis to maintain efficiency and to ensure high water quality. These cartridges work together and must be replaced every 6-12 months. Any significant change in performance of the system should be investigated promptly to avoid secondary damage or deterioration to other parts of the system.

**CAUTION:** Improperly installed systems could result in water damage due to leaks or flooding. Proper installation of this system requires familiarity with standard sink plumbing and proper use of common hand and power tools. If you are not familiar with standard sink plumbing and proper use of common hand and power tools or have any difficulty with the installation of this system, consult a licensed professional, such as a contractor or plumber.

**NOTE:** This system has been designed for installation by licensed professionals, such as a contractor or plumber.



Stage	Description	Cap Color	Replacement Interval
1 & 2	20 micron sediment prefilter plus granular activated carbon.	Green	6-12 months
3	Reverse osmosis membrane	White	12 months
4	Granular activated carbon post-filter	Blue	6-12 months

### System Performance

Daily production rate 42.8 L/d (11.3 gpd)  
 Total Dissolved Solids Reduction 96.4%

### Feed Water Requirements

Feed Water Potable, municipal water  
 Feed Pressure 40psi - 80psi  
 Feed temperature 40°F to 100°F  
 Total dissolved solids 2,000 mg/L max  
 Chlorine <1.0 mg/L max.  
 pH 4-8  
 Turbidity <1.0 NTU  
 SDI <5  
 Iron, Manganese, Hydrogen Sulfide 0 ppm

***Do not use with water that is microbiologically unsafe or of unknown quality without adequate disinfection before or after the system.***

# SIERRA Warranty

This Limited Warranty extends to the original purchaser of the system only. This warranty covers all Manufacturer-supplied items only that prove to be defective in material, workmanship or factory preparation. This warranty covers parts only; all labor is excluded from this warranty, including, but not limited to, services related to the removal, replacement, installation, adjustment, maintenance and/or repair of the unit or its components items. excludes all non-Manufacturer labor required for any servicing of the unit, including, but not limited to, servicing related to installation, adjustment, maintenance and repair of the unit. This warranty applies only for the first full calendar year from date of purchase. The following items are excluded from this warranty: membranes, filters, O-rings, and all other parts or components that require regular replacement as a result of ordinary usage.

**Disclaimers:** This Limited Warranty applies only if the system is installed, used and maintained in compliance with all instructions and requirements enclosed with the system. This warranty will be void for failure to observe the following conditions:

1. The system is to be used with potable water from a municipal water system.
2. Feed water pressure to the unit is no less than 40 PSI and no greater than 80 PSI.
3. The system is to be used on water supplies with chlorine concentrations of 1.0 mg/L (ppm) or less.
4. Feed water temperature to the unit must be no less than 40°F and no more than 100°F.
5. Total dissolved solids in feed water must be less than 2,000 mg/L (ppm).
6. Feed water must have a pH between 4 and 8.
7. Turbidity must be less than 1.0 NTU.
8. SDI must be less than 5.
9. Feed water must be completely free of iron, manganese or hydrogen sulfide.

**Do not use with water that is microbiologically unsafe or of unknown quality without adequate disinfection before or after the system.**

The Manufacturer does not know the characteristics of your water supply. The quality of water supplies may vary seasonably or over a period of time. Your water usage may vary as well. Water characteristics can also change if the drinking water appliance is moved to a new location. The Manufacturer assumes no liability for the determination of the proper equipment necessary to meet your requirements, and we do not authorize others to assume such obligation on our behalf.

This Limited Warranty does not cover any Manufacturer-supplied items that are defective as a result of the use of improper parts, equipment or materials. This warranty does not cover alterations or modifications of the unit, or failure of a unit caused by such alterations and modifications

This Limited Warranty does not cover malfunctions of the unit due to tampering, misuse, alteration, lack of regular maintenance, misapplication, fouling due to hydrogen sulfide, manganese or iron, scaling from excessive hardness, turbidity greater than 1.0 NTU, Silt Density Index (SDI) greater than 5.0 SDI, or excessive membrane hydrolysis due to chlorine levels in excess of 1.0 mg/L (ppm). In addition, damage to the unit due to fire, accident, negligence, act of God, or events beyond the control of the Manufacturer are not covered by this warranty.

**Incidental and Consequential Damages Limitation:** The Manufacturer will not be responsible for any incidental or consequential damages as a result of the failure of this unit to comply with express or implied warranties or any defect in the unit, including but not limited to, lost time, inconvenience, damage to personal property, loss of revenue, commercial losses, postage, travel, telephone expenditures, or other losses of this nature. Some states do not allow the exclusion or limitation of incidental or consequential damages, so this exclusion may not apply to you.

**Owner's Warranty Responsibilities:** As a condition of this Limited Warranty, the owner must ensure periodic maintenance of the system is performed as described in the literature enclosed with the system. Neglect, improper maintenance, abuse, modification or alteration of the unit will invalidate this Warranty. Should your unit develop a defect or otherwise fail to perform in accordance with this warranty, you should contact the retailer from whom the product was originally purchased.

**Implied Warranties:** The implied at-law warranties of merchantability and fitness for a particular purpose shall terminate on the date one year after the date of purchase. Note: some states do not allow limitations on how long an implied warranty lasts, so the above limitations may not apply to you.

**Other Rights:** This Warranty gives you specific legal rights and you may also have other rights which vary from state to state.

# SIERRA Installation Overview

The following instructions outline a typical water treatment system installation. Consult local plumbing codes and building regulations as they may pose different or additional requirements for the installation. The installer is responsible for ensuring that the installation is in compliance with all applicable state and local regulations.

This system has been designed for installation by a licensed professional such as a contractor or plumber. Proper completion of this installation will require basic familiarity with standard sink plumbing and proper use of common hand and power tools. Improperly installed systems could result in water damage due to leaks or flooding.

**Typical Installation Diagram**

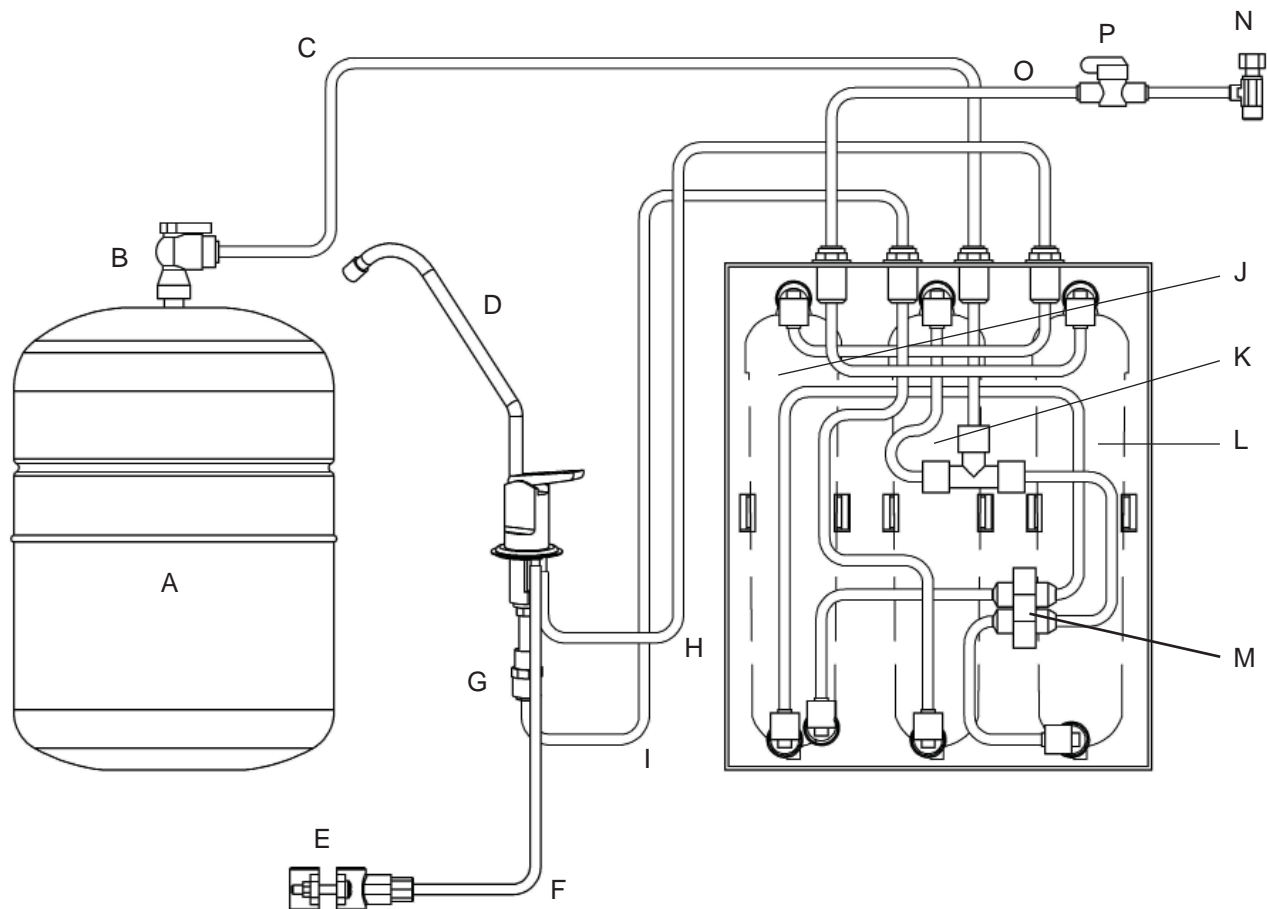

- |    |                            |    |                                  |
|----|----------------------------|----|----------------------------------|
| A. | Product water storage tank | I. | Product water tubing (3/8" blue) |
| B. | Tank shut-off valve        | J. | Reverse osmosis membrane filter  |
| C. | Tank tubing (3/8" white)   | K. | Carbon post-filter               |
| D. | Air-gap faucet             | L. | Sediment/carbon pre-filter       |
| E. | Drain connection assembly  | M. | Automatic shut-off valve         |
| F. | Drain tubing (3/8" white)  | N. | Inlet fitting                    |
| G. | Quick-connect fitting      | O. | Feed water tubing (1/4" green)   |
| H. | Drain tubing (1/4" yellow) | P. | Feed water shut-off              |

# SIERRA Feed and Drain Connections

## Feed Connection

1. Locate and turn off the angle stop valve on the cold water line feeding the sink. This valve will usually be located under the sink on the pipe coming out of the wall.
2. When the angle stop valve is closed, relieve pressure in the line by opening the cold water tap on the sink.
3. Disconnect the cold water faucet feed line at the angle stop valve.
4. Install the feed adapter into the angle stop. (Fig. 1)
5. Firmly press the green 1/4" tubing into the 1/4" connector on the feed adapter.
6. Connect the cold water faucet feed line into the feed adapter.
7. Attach the small feed valve warning tag from the parts bag to the feed valve.
8. Attach the Shutoff Warning label to the system so that it is directly visible. Fill out the Date of Installation label and attach to the side of the system.



Fig. 1

## Drain Connection

*Note: The drain saddle assembly must be installed before the 'P' trap. Do not install the drain saddle assembly between the 'P' trap and the wall.*

1. Position drain saddle assembly (Fig. 2) on drain pipe under sink between the P trap and the sink connection.
2. Orient the drain saddle so that the connector opening points in the general direction of the planned location for the R.O. dispensing faucet.
3. Using the connector opening in the side of the drain saddle as a guide, drill a 3/8" hole through the wall of the drain pipe. (Fig. 3)
4. Remove drain saddle assembly. Place the adhesive foam pad over the 3/8" hole in the drain pipe. Replace the assembly onto the drain pipe, aligning the hole in the drain with the hole in the drain assembly.
5. Tighten the saddle bolts evenly on both sides until the saddle grips the pipe snugly - do not overtighten. (Fig. 3)
6. Insert the drain tube from the R.O. dispensing faucet through the drain saddle connector nut. Tighten the connector nut onto the drain saddle.

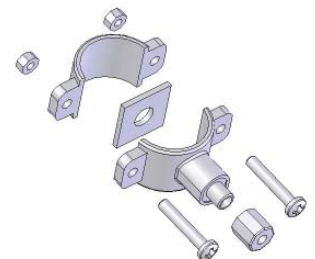

Fig. 2

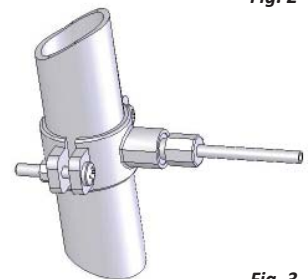
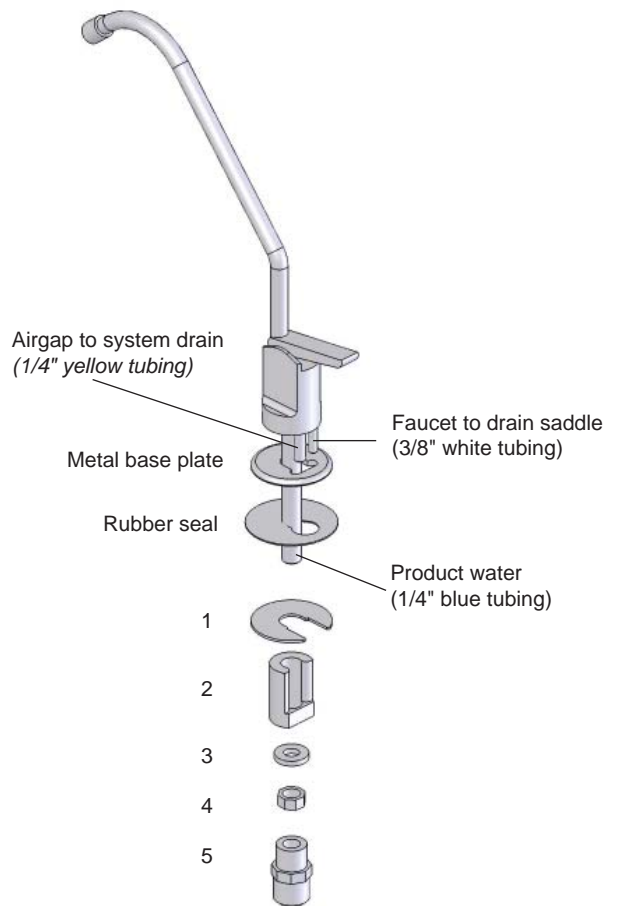

Fig. 3

# SIERRA Push Handle Airgap Faucet

For easier installation, attach all tubing prior to mounting the faucet.

1. Insert polished faucet base onto base of faucet.
2. Push the 1/4" yellow drain tubing onto the 1/4" barb fitting. This tube must be of sufficient length to reach the yellow drain connection on the manifold.
3. Push the white 3/8" tubing onto the larger 3/8" barbed fitting, being sure you have enough tubing to reach the drain saddle.
4. Slip the 1/4" and 3/8" tubing through opening in polished faucet base. Slide white plastic spacer open-end-up onto the threaded faucet stem (2).
5. Thread the 3/8" washer (3) and mounting lock nut (4) onto the threaded stem. (Fig 6)
6. Thread faucet quick-connect adapter (5) on to threads of faucet stem. NOTE: This connection should be hand-tightened only. Push one end of 3/8" blue tubing into 3/8" connection.
7. Insert tubing and faucet assembly down through the sink hole.
8. Position the faucet to the desired handle orientation. Slip the slotted washer (1) between the white plastic spacer and the sink. Securely hand tighten the mounting nut.
9. Connect the white 3/8" tubing to the drain saddle assembly using the drain connector nut supplied. This tubing should follow as direct a path as possible; long runs, looping or deep sags will restrict normal brine flow to the drain. Save the unused portion of the tubing for the installation of the storage tank.
10. Apply a small amount of silicone-based lubricant to the O-rings located at the base of the spout. Firmly insert spout assembly into the top hole of faucet body (approximately 1/4"). You may swivel the faucet left or right.



# SIERRA Manifold Installation

Determine the most practical under-the-sink location for placement of the Sierra manifold unit and the companion reservoir tank. Ensure that the specific location allows adequate access to the manifold unit for cartridge replacement and to the tank for tank- valve operation.

1. Place the manifold and tank in the selected locations. If desired, the #6 self tapping screws may be used to secure the manifold unit in position by means of the top rear and bottom lip mounting holes.
2. Take the unused portion of the 3/8" white tubing and insert one end firmly into the 3/8" (largest) connector on the top of the manifold unit.
3. Extend the 3/8" white tubing from the manifold unit to the tank valve. Leave enough slack in the tubing to allow the unit to be removed from the installed location for servicing. Cut off the excess and insert the 3/8" tube into the quick-connect tank valve fitting until it is fully engaged.
4. Extend the 1/4" yellow tubing from the faucet unit to the manifold. Leave enough slack in the tubing to allow the unit to be removed from the installed location for servicing. Cut off the excess and firmly insert the tubing into the corresponding yellow drain connection located on the manifold.
5. Extend the 3/8" blue tubing from the faucet unit to the manifold. Leave enough slack in the tubing to allow the unit to be removed from the installed location for servicing. Cut off the excess and firmly insert the tubing into the corresponding blue product water connection located on the manifold.
6. Extend the green tubing from the feed connector valve to the manifold. Leave enough slack in the tubing to allow the unit to be removed from the installed location for servicing. Cut off the excess and firmly insert the tubing into the corresponding green feed connection located on the manifold.
7. Obtain the Shutoff Warning label and affix it to the manifold unit so that it is directly visible. The Sierra system is now connected and ready for initial test and preparation.

**TUBING HINTS:** Use a sharp knife or tubing cutter to cut the tubing squarely, being sure to remove all burrs. Then insert the tubing firmly until it stops. To remove the tubing, push against the collet while pulling on the tubing.



# SIERRA System Activation and Flushing

## System Activation

1. Check all tubing connections to ensure they are firmly seated. CHECK TO SEE THAT THE CARTRIDGE RETAINER CLIPS AND LOCKS ARE PROPERLY ENGAGED. Failure to keep the retaining clips in place could result in accidental leaks and flooding.
2. Open the dispensing faucet at the sink. Close the tank shut-off valve.
3. Open the feed water valve to the system. Observe all tubing and connections for several minutes to detect any leaks. In approximately 5 minutes, (assuming normal feed water pressure) the dispensing faucet should begin dripping.
4. Place a pan or other temporary water basin near the drain 'P' trap. Loosen the connector nut holding the 3/8" tube in the drain saddle connector. Pull the tube out of the connector and use the pan to catch any water that may spill. Brine water should be flowing from the tube. Reconnect the tube to the drain saddle and hand-tighten the connector nut.
5. Allow the faucet to run for up to 15 minutes, then close the faucet.
6. Check connections for leaks.
7. Open the tank shut-off valve.

## Initial Flushing Procedure

1. Before the system can be used for drinking water production it must be adequately flushed. Each reservoir tank is dosed with a small amount of powdered chlorinated sanitizer before shipment in order to ensure tank internal cleanliness. Also, the carbon filter cartridges will release a small amount of carbon fines during the first tankful of flow. This flushing procedure will allow any sanitizer or carbon fines to pass from the system.
2. Initial tank filling will take approximately two and one half hours (based on average feed pressure). When the tank is full, the water pressure will have risen to the point where the automatic shut-off valve inside the unit will stop the feed flow through the system. Actuation of the automatic shut-off valve can be determined by checking for a lack of brine flow to the drain saddle. When the tank has filled for the first time, it should be left undisturbed for at least 8 hours to ensure proper sanitization.
3. After 8 hours have elapsed, open the dispensing faucet fully and allow the product water to run out to drain at maximum flow. The initial discharge will be dark with the bulk of the carbon particle wash out. There may also be the scent of chlorinated water from the sanitizing agent. When the flow has diminished to a fast drip or small stream, close the dispensing faucet.
4. Fill and flush the tank at least three times prior to use. If necessary, repeat until the chlorination scent has disappeared. It is important that the flush be done at maximum flow (e.g. the tank must be full) to assist in rapid wash out. After this flushing procedure the system is ready for normal use.

# SIERRA Checklist

1. System is located where it will not be subject to physical impacts or rough contact by heavy objects.
2. Feed water pressure to the unit is no less than 40 psi and no greater than 80 PSI.
3. Ensure the plastic retainer clips that holds the cartridges in place are fully engaged and locked in place. The slide locks must snap into place in the slots. If the clip does not snap easily into place through the slots it means the cartridge is not fully inserted into the connectors. Press top or bottom of cartridge to engage connectors until it snaps into place properly.
4. All tubing connections, especially push-in quick connections, are fully inserted.
5. Tubing connected between the faucet and the drain saddle fitting (the fitting attached to the sink drain pipe) runs "downhill" to the drain. There should be no loops or places where water would not flow out to the drain.
6. Feed water valve is open.
7. Within one to two hours after initial application of water pressure, check again for leaks especially at the tank, faucet tubing and connectors. These parts will not see full pressure until approximately 2 hours after the system is activated.
8. Flush three tankfuls of product water to drain. If a chlorine scent persists, repeat flushing procedure.

# SIERRA Cartridge Replacement

1. Close the feed water shut-off valve.
2. Close the tank shut-off valve.
3. Open the dispensing faucet to relieve system pressure. Close dispensing faucet when flow has stopped.
4. Pull the unit from the installed location.
5. Remove the retaining clip from the front of the unit. Pull the cartridge off the unit evenly at top and bottom. Dispose of used cartridge.
6. Install the new cartridge, rocking gently from side to side as necessary until the cartridge tubes are properly engaged in the unit connectors. Install the retaining clip, ensuring the slide locks snap into place in the slots. If the clip does not snap easily into place through the slots it means the cartridge is not fully inserted into the connectors. Press the top or bottom of the cartridge to engage the connector so that it snaps fully into place.
7. Repeat Steps 5 and 6 for each cartridge to be replaced.
8. Turn on feed water shut-off valve and open dispensing faucet.
9. Close dispensing faucet after water starts running.
10. Observe system for any leaks, especially at newly replaced cartridge.
11. Open the tank shut-off valve.
12. If replaced cartridge was a post carbon or a membrane filter, the system should be flushed at least once as described in the previous section - Activation and Flushing.